



SCA SERIES

Replacement Chassis for
Singer/McQuay HC
Heat Pump



Product Benefits

- OEM Quality Replacement
- Reliable Operation
- Low Sound Level
- Fast and Easy Replacement
- Damage Protection

SHOREFIT® SCA SERIES

Replacement Chassis for Singer/McQuay HC Series

The Shorefit® SCA series replacement chassis provides environment friendly, high efficiency cooling and heating where individual, quiet control is a priority. This application flexible unit is also a direct replacement for Singer/McQuay HC, EH (models 070, 090, 120, 140, 180, and 240) series vertical stacked water source heat pump chassis. The chassis is a part of a complete system, which consists of the chassis, blower section, control box, and furred-in room cabinet with risers. The chassis contains the compressor, air side heat exchanger, water side heat exchanger, and refrigerant circuit control and safety components.

The SCA is dimensionally identical to the original for a fast, easy, and trouble-free installation. Quality components, careful design and testing and the latest in environment friendly technology mean long unit life, user satisfaction and lower energy costs. Shorefit® is the replacement solution for upgrading old, worn out, inefficient original chassis. The extensive list of unit features includes:

- Quiet, durable, and efficient compressor with built-in pressure and temperature protection
- Heavy gauge G90 galvanized steel construction
- Powder painted drain pan
- High efficiency copper tube-aluminum fin evaporator coil
- High efficiency coaxial condenser coil with low water-side pressure drop
- Lock out circuit* with reset at thermostat or circuit breaker
- High Pressure switch
- Frost-free cooling
- Water coil freeze protection
- Refrigerant circuit access ports
- Precision selected capillary tube refrigerant control
- Positive shift reversing valve
- Suction Accumulator
- Precision charged with R-410A refrigerant
- 1/2 Inch FPT water connections
- Chassis pull handle facilitates easy chassis removal and handling
- 1 Inch fiberglass or natural fiber air filter

* Model specific. May include lock out circuit, five minute anti-short cycle timer or interconnect control utilizing control panel logics.

Performance Ratings - Shorefit® SCA

Model	Cool Btuh*	Sens Btuh	EER**	Heat Btuh*	COP*	CFM (Design)	GPM	Coil PD	Refrigerant
SCA-08	8,300	5,800	14.1	9,800	4.4	250	2.0	1.2'	R-410A
SCA-10	9,800	7,200	13.4	11,900	4.2	315	2.4	1.8'	R-410A
SCA-12	12,300	9,400	12.6	15,000	4.2	400	3.0	3.4'	R-410A
SCA-15	15,600	12,100	15.6	17,500	4.6	550	3.0	3.4'	R-410A
SCA-20	20,600	15,000	14.5	23,200	4.4	635	4.5	3.2'	R-410A
SCA-24	26,000	18,800	14.6	29,100	4.4	800	6.0	6.4'	R-410A

Continuous engineering improvements may result in performance changes without notice.

* Includes 1250Btu/1000 CFM fan heat and 365w/1000 CFM fan power. Fan power and pumping corrections are not included for rating purposes. 208v data shown. 115v and 265v ratings may vary.

Unit Sizes

Model	A	B	C	D	E	Chassis Weight (lbs)
	Inches					
SCA-08	17.6	18.7	41.0	12.0	12.7	75
SCA-10	17.6	18.7	41.0	12.0	12.7	80
SCA-12	17.6	18.7	41.0	12.0	12.7	85
SCA-15	17.6	18.7	41.0	12.0	12.7	90
SCA-20	17.6	18.7	41.0	12.0	12.7	105
SCA-24	17.6	18.7	41.0	12.0	12.7	125

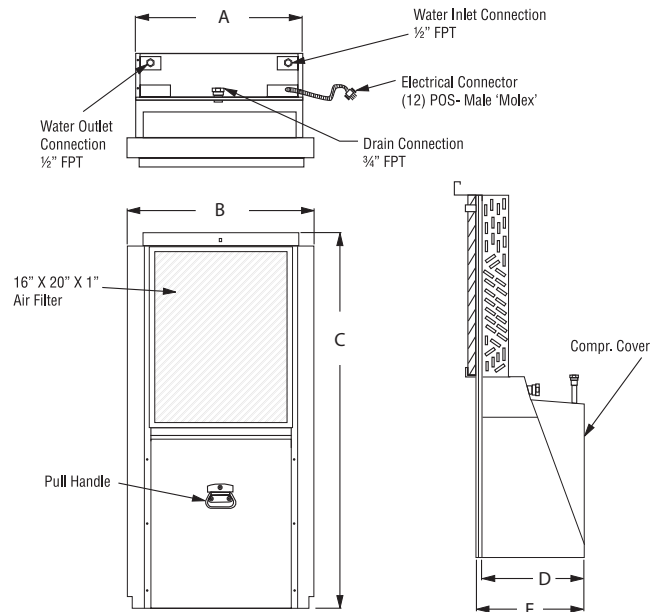

APPLICATION & BENEFITS

Fast and Easy Replacement

The Shorefit® SCA series replacement chassis fits the existing Singer/McQuay HK room cabinets and works with the existing blower section and control box without modification. Because the chassis dimensions and construction details are like the original, replacement work is fast and easy. The chassis installs without the need for water loop shut-down or draining. A chassis pull handle is provided to facilitate easy removal and handling. Water, drain and electrical connections line right up to the original installation. The electrical connectors plug directly into the control box connectors. Using Shorefit® replacements eliminates the need for room renovation, redecorating, and piping changes and is the solution that gets your property back in service quickly and at the lowest total cost.

Damage Protection

The standard high-pressure switch and evaporator coil freeze protection stops unit operation before damage occurs, should airflow become reduced or obstructed due to dirty coils, obstructed airflow, or motor failure or lock up. A freezestat protects the water coil from freeze damage due to water temperature or flow problems. The water coil is designed for low water-side pressure drop, eliminating potential pump sizing and water flow problems.

Options and Accessories

- Blower sections
- Return air panels
- Control options
- 115V, 265V/277V (Availability varies by model sizes)
- Hose kits
- Flow control valve

Warranty

All units are provided with a 12-month parts warranty (from date of ship) for all components.

Note: The replacement chassis performance is based on providing the proper airflow through new chassis. Existing fan assemblies affect airflow due to corrosion and caked-on dirt. Fan motors affect airflow due to age or improper specifications. Cleaning / repair / replacement of blowers is required prior to installation of new chassis. New fan/motor assemblies allow your replacement chassis to perform properly for years to come.

Electrical Data

Model	Compressor Type	Voltage Volt-Hz-Ph	RLA	LRA	Total Amps	Ckt Amps	Max Fuse	Min Volts
SCA-08	Rotary	208/230/60/1	3.0	15.0	3.0	4.0	15	197
SCA-08	Rotary	265/60/1	2.7	11.0	2.7	4.0	15	240
SCA-10	Rotary	208/230/60/1	3.7	22.0	3.7	5.0	15	197
SCA-10	Rotary	265/60/1	3.5	22.0	3.5	5.0	15	240
SCA-12	Rotary	208/230/60/1	4.7	25.0	4.7	6.0	15	197
SCA-12	Rotary	265/60/1	4.2	22.0	4.2	6.0	15	240
SCA-15	Rotary	208/230/60/1	5.6	29.0	5.6	7.0	15	197
SCA-15	Rotary	265/60/1	5.0	28.0	5.0	6.0	15	240
SCA-20	Rotary	208/230/60/1	7.4	33.0	7.4	10.0	15	197
SCA-20	Rotary	265/60/1	6.0	28.0	6.0	8.0	15	240
SCA-24	Recip.	208/230/60/1	7.4	43.0	7.4	10.0	15	197
SCA-24	Recip.	265/60/1	6.7	46.0	6.7	8.0	15	240



THE SHOREFIT® DIFFERENCE

Shorefit® HVAC products are engineered to exceed OEM specifications in these and other applications:

- Hotels
- Condominiums
- Dormitories
- Apartments
- Senior Living Facilities
- Offices

Replacement Products that are Sure to Fit

Shorefit® HVAC relies on years of experience and product innovation synonymous with The Whalen Company to develop products that are sure to fit your application. Our long-term commitment to this endeavor assures you of systems that are high quality, operate reliably and provide the best value to the customer. To learn more about how Shorefit® can help you save time and money on your next project, contact your local Shorefit® representative, call **410-822-9200** to speak with one of our specialists, or e-mail your request to sales@shorefithvac.com.

Shorefit® provides customer support, replacement parts, and OEM style replacement products designed and engineered to meet and exceed original factory specifications in order to keep your comfort system running at peak performance. Utilizing an independent sales representative network across North America, help is not far away. Make sure that your next retrofit project runs smoothly by putting Shorefit® to work for you.

**Shorefit® is a registered trademark of The Whalen Company*

Your Shorefit® Representative:



P.O. Box 1390 • Easton, MD 21601 USA
Tel. 410-822-9200 • Fax: 410-822-8926
www.shorefithvac.com

